

Default setup of R11 MID upper deck.

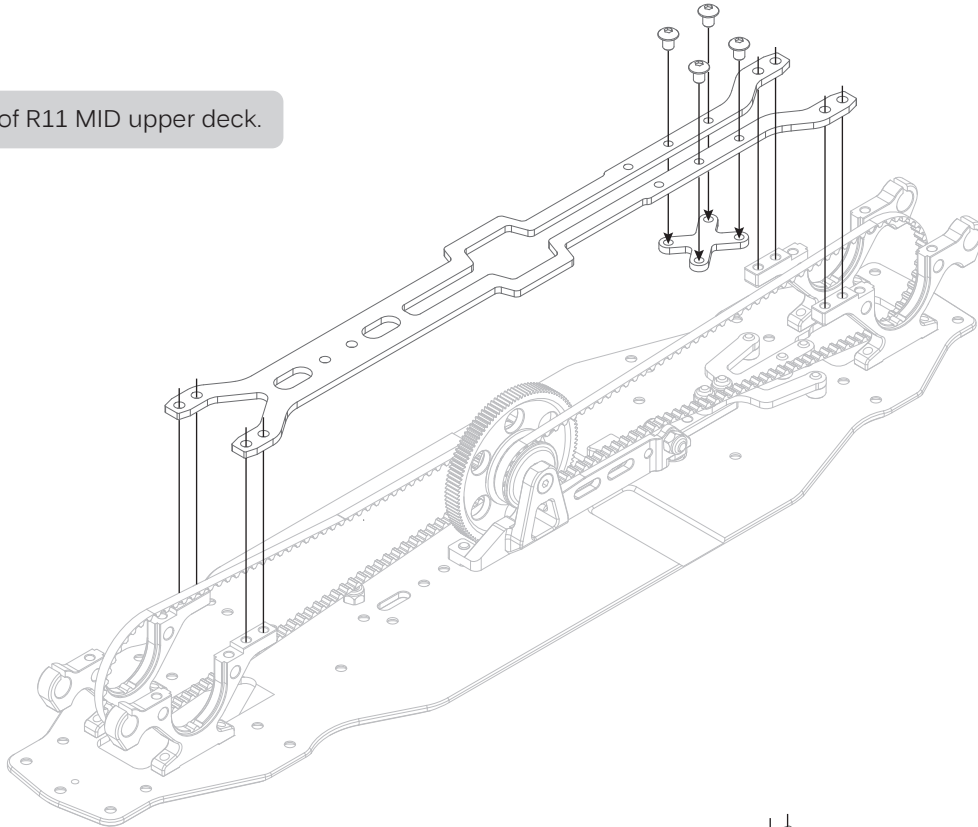

Reverse upper deck of R11 MID, more flex in front side for more steering.

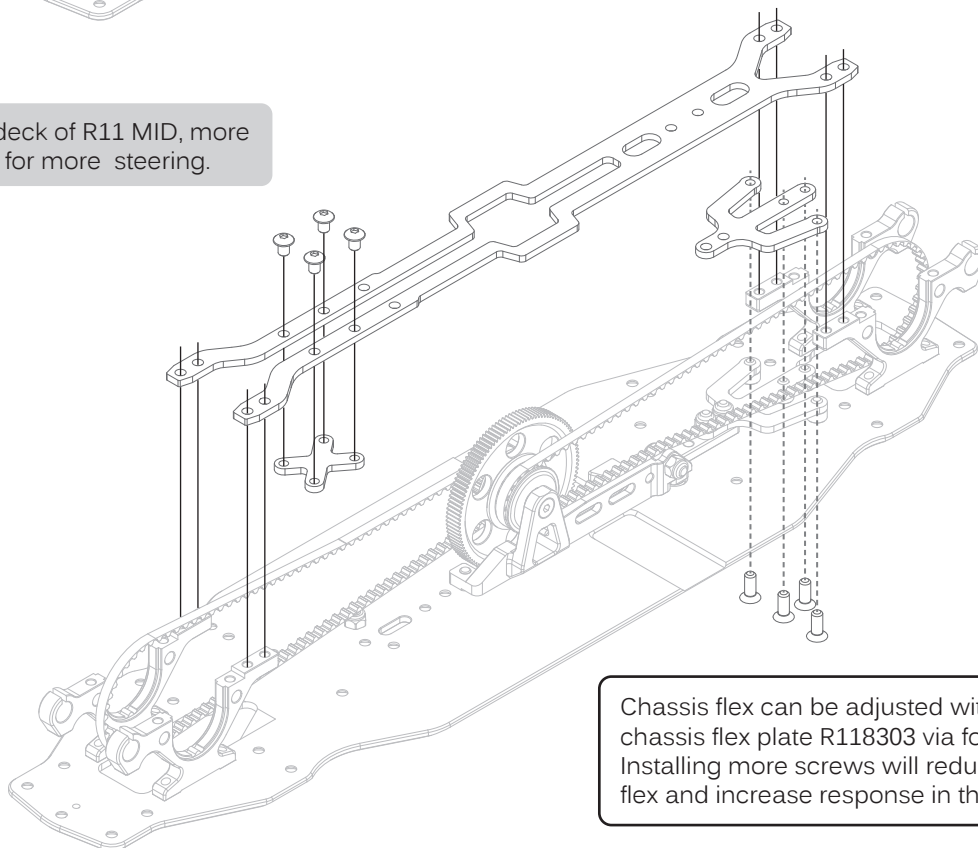

Chassis flex can be adjusted with the chassis flex plate R118303 via four screws. Installing more screws will reduce chassis flex and increase response in the rear end.

NOTICE

The upper deck for the R11 MID can be mounted in two different ways. The default setup has less flex at the front, making the R11 MID easier to drive. Reversing the upper deck will create more flex in the front end to provide the car with more steering. The X-shaped upper deck flex plate can be installed in different locations to enable you to fine tune the flex response according to track conditions.

Only R11 2018 & R11 2019 able to convert into R11 MID